

BOD 63M-LB04-S115
BOD0011

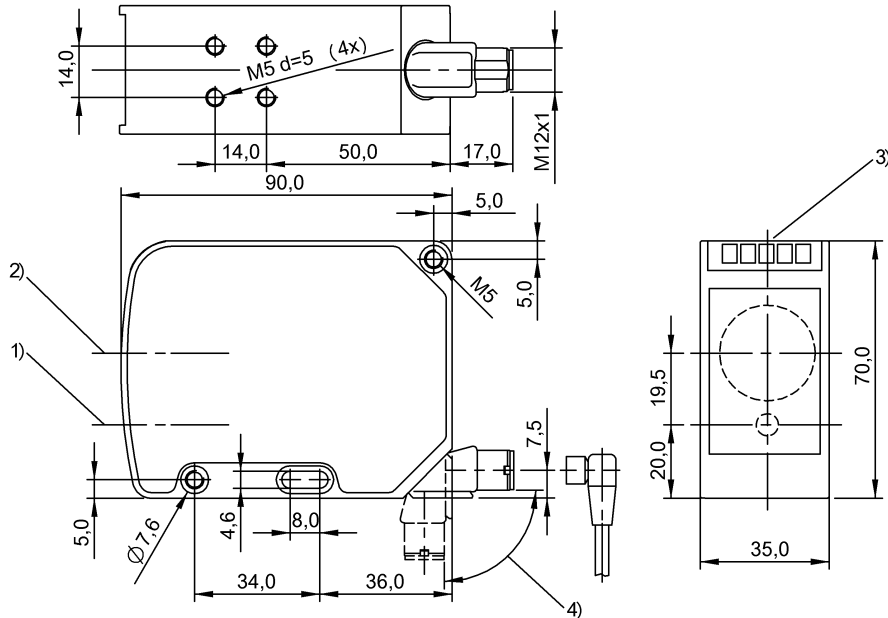

1) Optical axis emitter 2) Optical axis receiver 3) Display and control panel 4) rotatable 270°



IND. CONT. EQ
8112
for use in the secondary of
a class 2 source of supply
Environmental - Type 1 Enclosure

Display/Operation

Adjuster	Potentiometer 4-turn (2x)
Setting	Rated switching distance (Sn)

Electrical connection

Connection	M12x1-Connector, 8-pole, A-coded
Contact, surface protection	Gold plated
Polarity reversal protected	yes
Short-circuit protection	yes

Electrical data

Hysteresis H max. (% of Sr)	0.3 %
Load capacitance max. at Ue	0.47 µF
Load resistance RL max. (Analog I)	500 ohms
Mean life expectancy	100,000 h, 25 °C
No-load current Io max. at Ue	75 mA
Operating voltage Ub	15...30 VDC
Output characteristic	linear increasing
Pollution degree	3
Pulse duration t max.	0.007 µs

Rated insulation voltage Ui	75 V DC
Rated operating current Ie DC	200 mA
Rated operating voltage Ue DC	24 V
Ready delay tv max.	20 ms
Repeat accuracy max. (% of Sr)	0.2 %
Residual current Ir max.	10 µA
Switching frequency	250 Hz
Turn-off delay toff max.	2 ms
Turn-on delay ton max.	2 ms
Utilization category	DC -13
Voltage drop Ud max. at Ie	2 V

Environmental conditions

Ambient temperature	-10...60 °C
Protection class	II
Protection type IEC 60529	IP67

Functional safety

Diagnostic coverage	0 %
Functional safety	no
Mission Time	10 a

BOD 63M-LB04-S115 BOD0011

General data

Application	Distance measurement
Approval/Conformity	cULus CE
Basic standard	IEC 60947-5-2, IEC 60947-5-7
Series	63M
Style	Square Connection can be rotated

Material

Housing material	Aluminum, Die casting
Material sensing surface	Glass
Surface protection	painted

Mechanical data

Dimension	35 x 70 x 90 mm
Fastening detail	Screw M4 Screw M5

Optical data

Ambient light max.	10000 Lux
Average power Po max.	1 mW
Beam characteristic	Collimated
Laser class per IEC 60825-1	2
Light type	Laser Red light
Principle of optical operation	Light time-of-flight
Wave length	660 nm

Output/Interface

Analog output	Analog, current, 4...20 mA
Input function	Emitter on/off
Supplementary output	Error output PNP
Switch function, supplementary output	Normally closed (NC)
Switching output	2x PNP Normally open (NO)

Range/Distance

Distance deviation 18 % max. (% of Sr)	1.5 %, S = 1000...6000 mm
Measuring range	200...6000 mm
Range	200...6000 mm
Rated operating distance Sn	6 m, Adjustable
Reproducibility	±2 mm
Resolution	≤ 1.0 mm
Ripple max. (% of Ue)	15 %
Temperature drift max. (% of Sr)	0.9 %

Remarks

Order accessories separately.
Full accuracy after warmup phase
Only for applications per NFPA 79 (machines with a supply voltage of maximum 600 V). Use an R/C (CYJV2) cable with suitable properties for attaching the device.
Reference object (target): gray card, 200 x 200, 90 % remission, axial approach.
The sensor is functional again after the overload has been eliminated.
For additional information, refer to user's guide.

Connector view

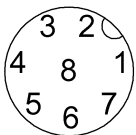

BOD 63M-LB04-S115
BOD0011

Wiring Diagram

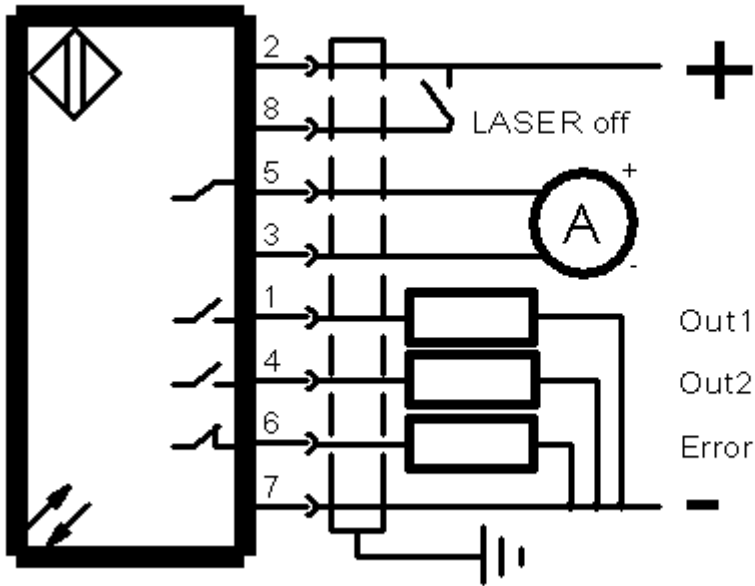

Diagram

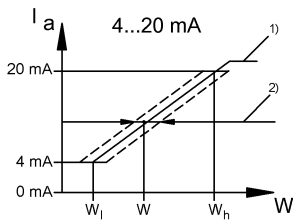

BOD 63M-LB04-S115
BOD0011

Additional View

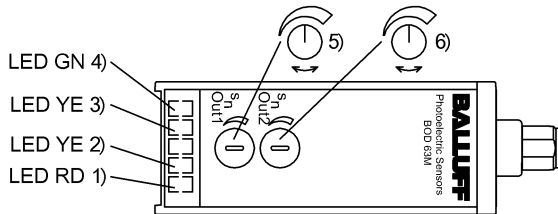

1) stability 2) Output function 3) Output function 4) Operating voltage 5) Sn Out1 6) Sn Out2

Symbols for Optoelectronic Sensors

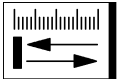

Warning Symbols

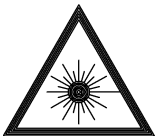

LASER BEAM - DO NOT STARE INTO THE LIGHT BEAM!

LASER CLASS 2 per IEC60825-1: 2003-10